

TYPICAL DETAILS FOR CLASSIC[®]



STELLAR
— WINDOWS · DOORS —

470.335.0294

info@stellarwd.com

www.stellarwd.com

5380 Peachtree Rd. Atlanta, GA 30341

CLASSIC[®]

SILL DETAIL

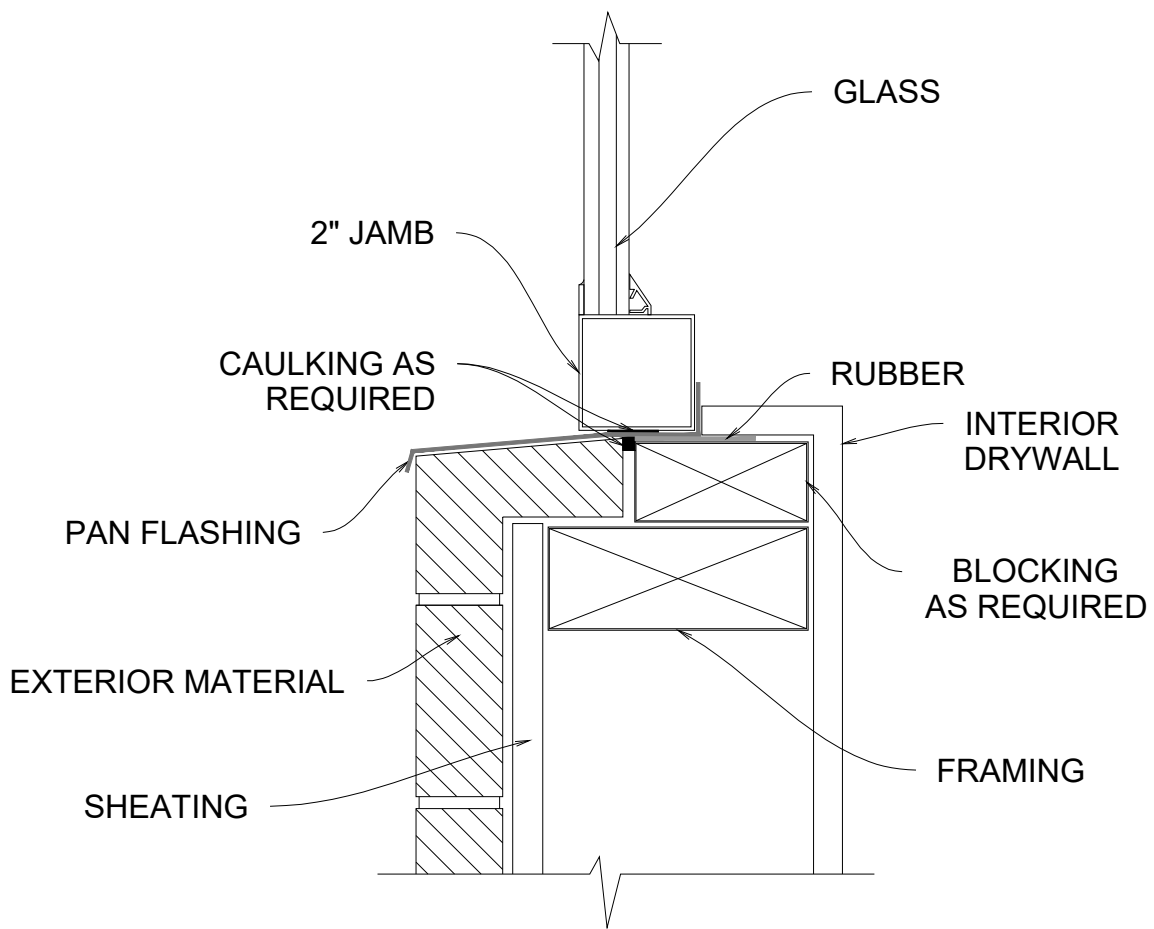

These details are recommendations only and for design consideration only.
They should not be used for construction and a design professional should be consulted for final construction drawings.
All units should be waterproofed both after the building wrap, and on completion of the exterior material.
ADDITIONAL DETAILS PROVIDED ON REQUEST



STELLAR
— WINDOWS · DOORS —

CLASSIC[®]

THRESHOLD DETAIL

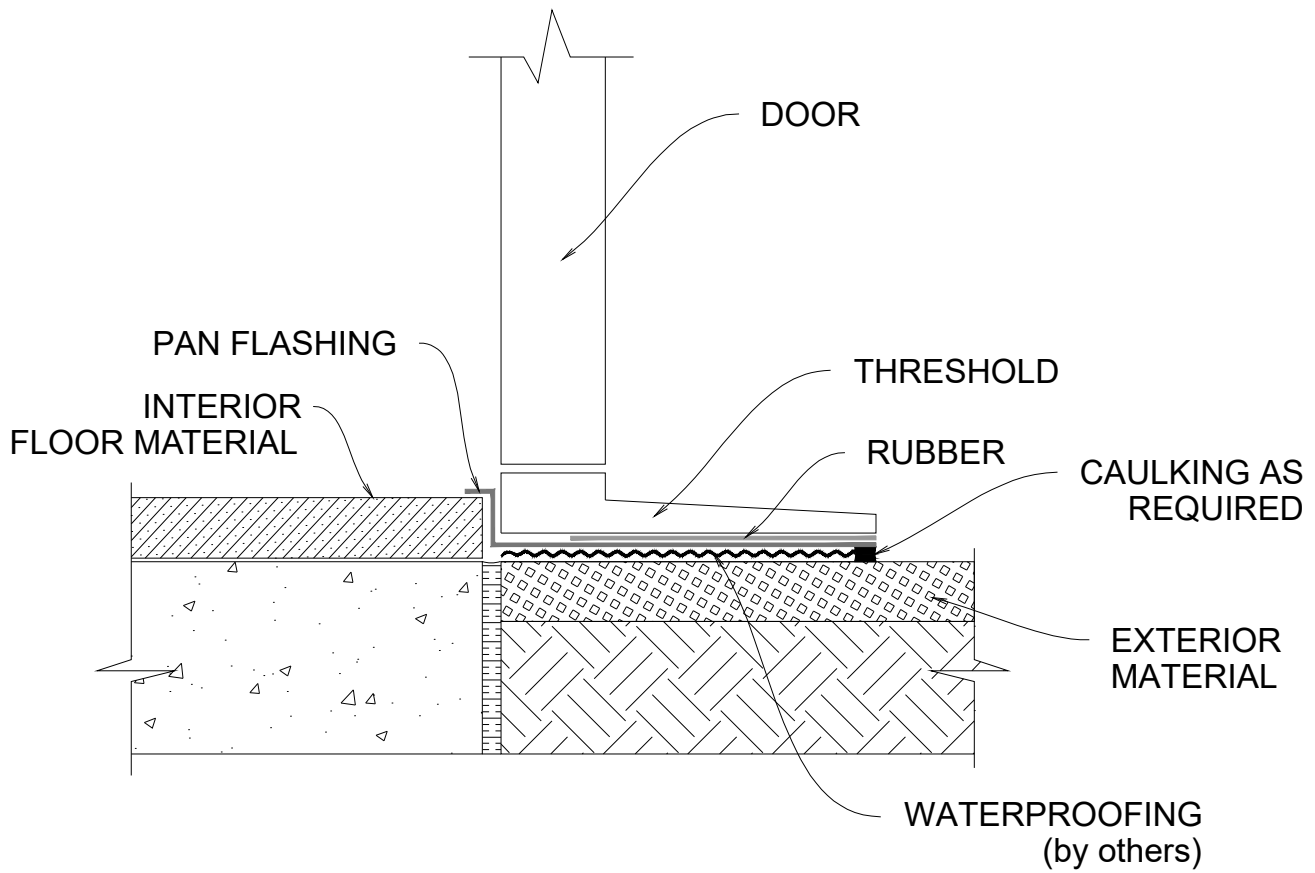

These details are recommendations only and for design consideration only.

They should not be used for construction and a design professional should be consulted for final construction drawings.

All units should be waterproofed both after the building wrap, and on completion of the exterior material.

ADDITIONAL DETAILS PROVIDED ON REQUEST

CLASSIC[®]

HEAD DETAIL

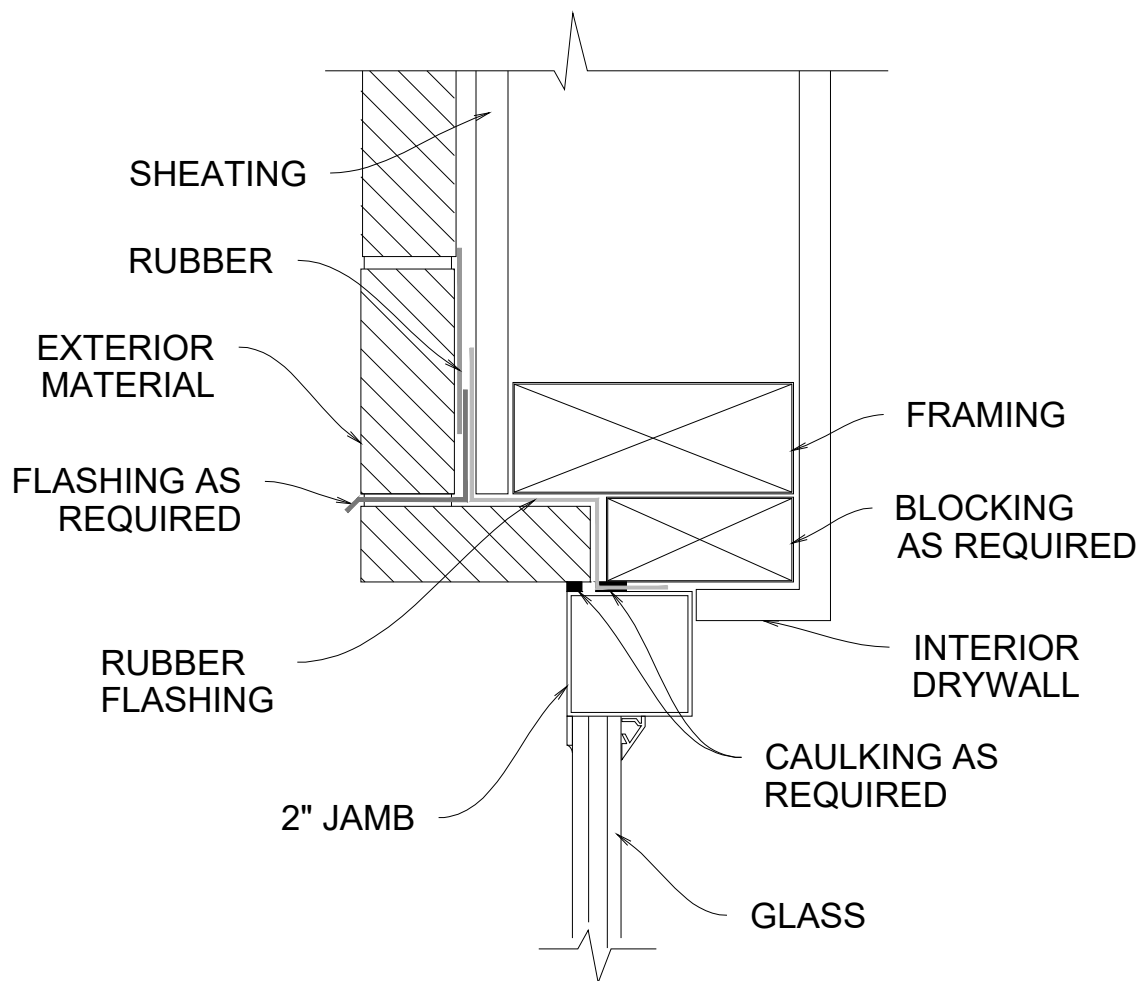

These details are recommendations only and for design consideration only.

They should not be used for construction and a design professional should be consulted for final construction drawings.

All units should be waterproofed both after the building wrap, and on completion of the exterior material.

ADDITIONAL DETAILS PROVIDED ON REQUEST



STELLAR
WINDOWS DOORS

DETAIL FOR WATERPROOFING

(CONSULT A DESIGN PROFESSIONAL FOR FINAL DETAIL)

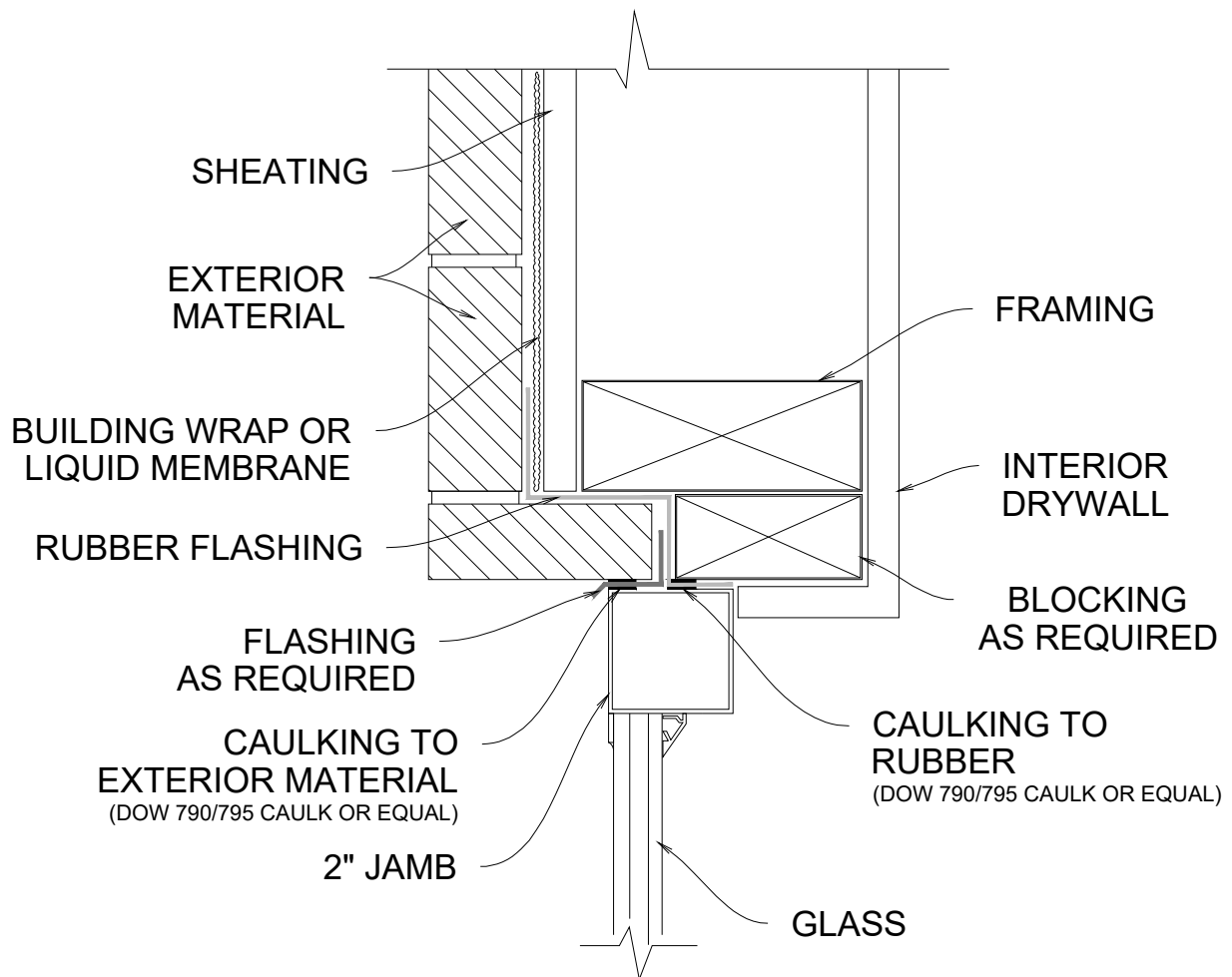

These details are recommendations only and for design consideration only.

They should not be used for construction and a design professional should be consulted for final construction drawings.

All units should be waterproofed both after the building wrap, and on completion of the exterior material.

ADDITIONAL DETAILS PROVIDED ON REQUEST