

TYPICAL DETAILS FOR SLIMLINE[®]



STELLAR
— WINDOWS • DOORS —

470.335.0294

info@stellarwd.com

www.stellarwd.com

5380 Peachtree Rd. Atlanta, GA 30341



SLIMLINE[®]

SILL DETAIL

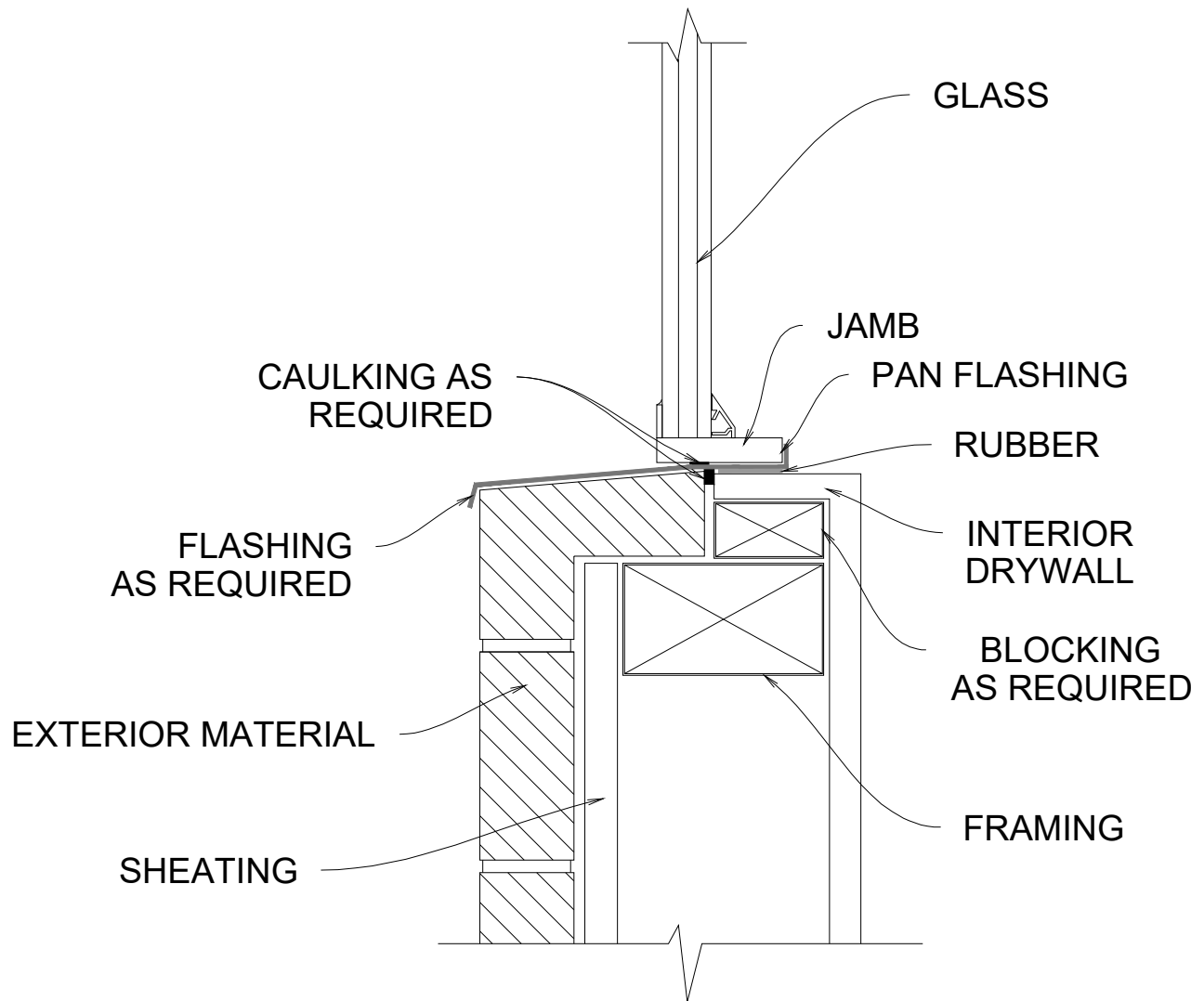

These details are recommendations only and for design consideration only. They should not be used for construction and a design professional should be consulted for final construction drawings. All units should be waterproofed both after the building wrap, and on completion of the exterior material. ADDITIONAL DETAILS PROVIDED ON REQUEST



SLIMLINE[®]

THRESHOLD DETAIL

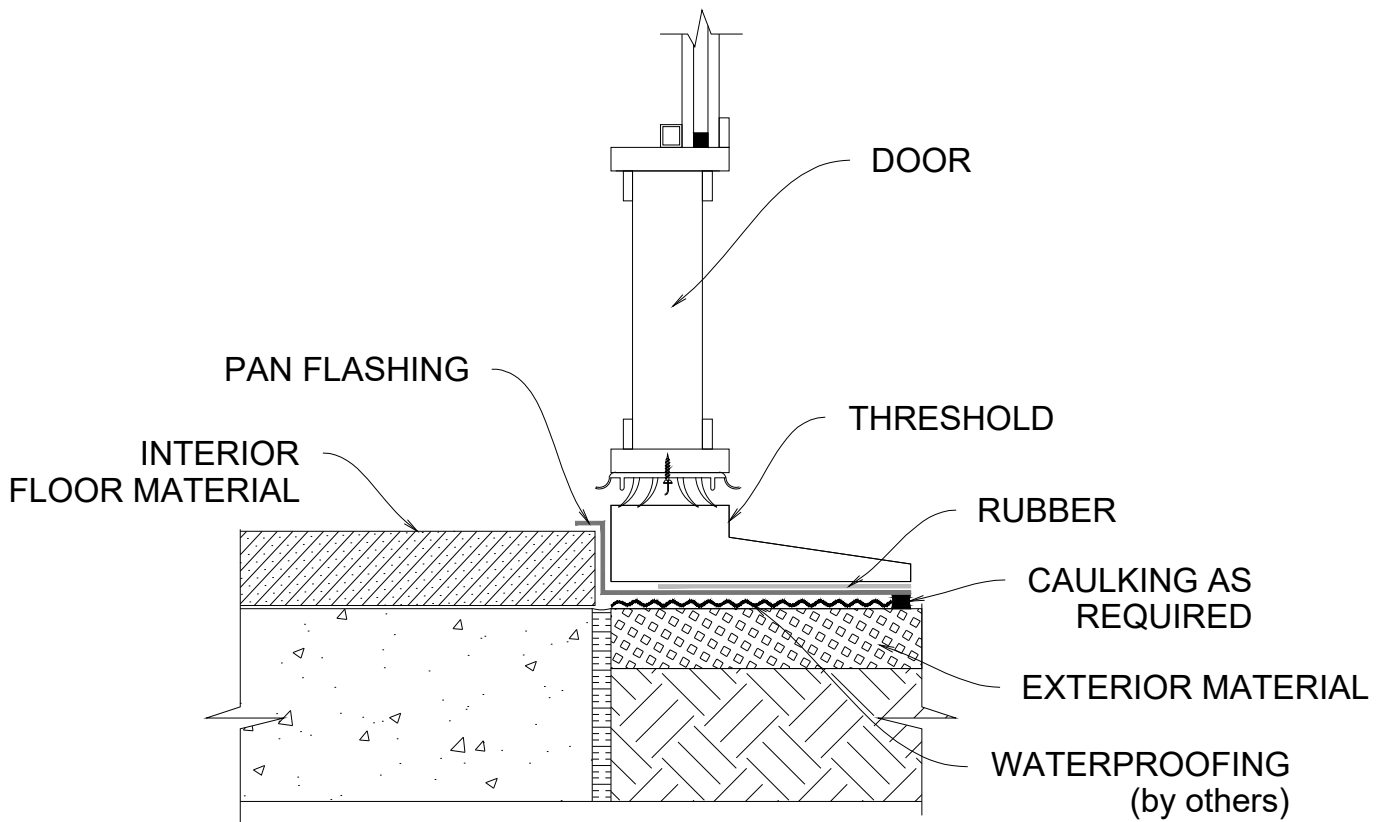

These details are recommendations only and for design consideration only.
They should not be used for construction and a design professional should be consulted for final construction drawings.
All units should be waterproofed both after the building wrap, and on completion of the exterior material.
ADDITIONAL DETAILS PROVIDED ON REQUEST



SLIMLINE[®]

HEAD DETAIL

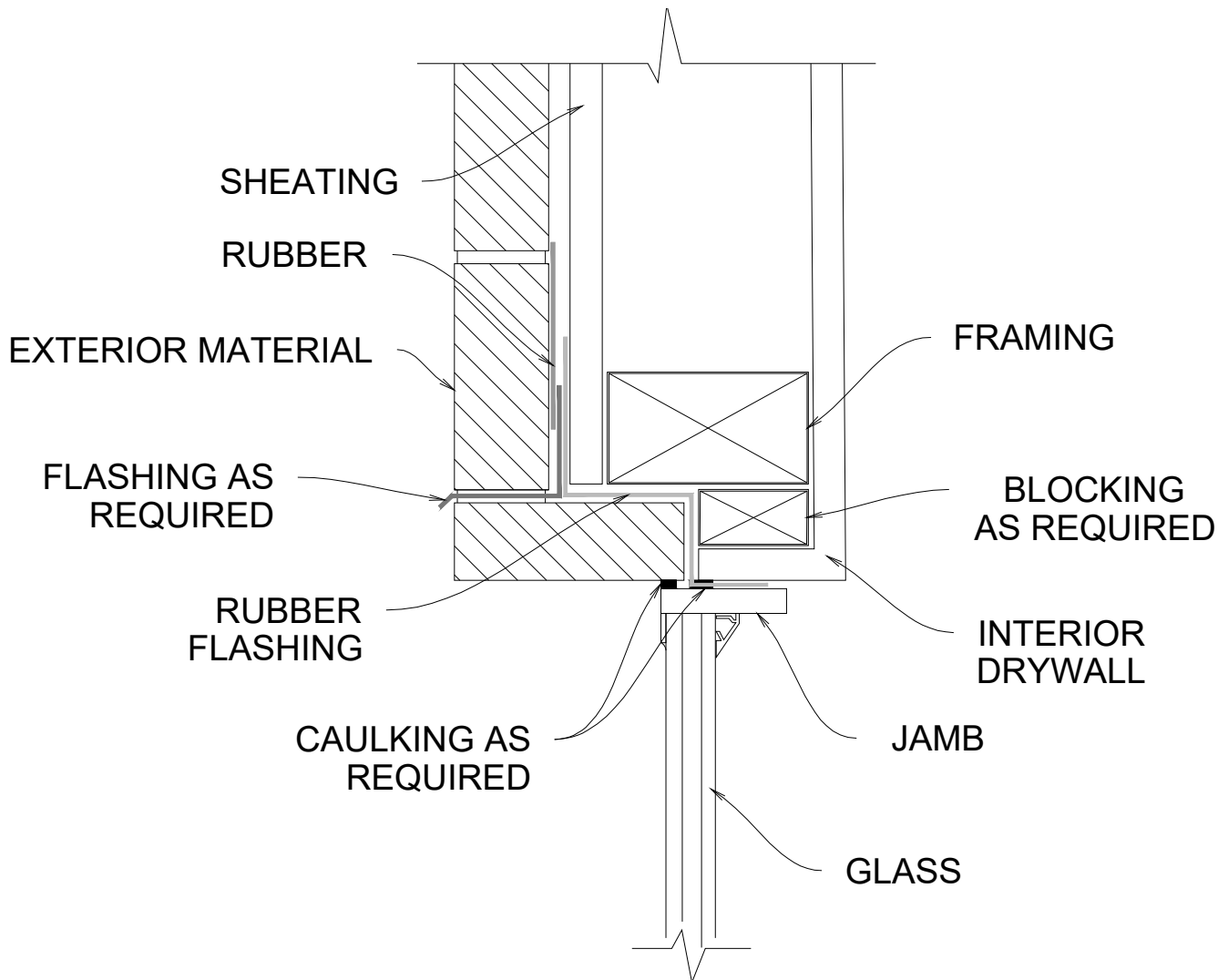

These details are recommendations only and for design consideration only.
They should not be used for construction and a design professional should be consulted for final construction drawings.
All units should be waterproofed both after the building wrap, and on completion of the exterior material.
ADDITIONAL DETAILS PROVIDED ON REQUEST

DETAIL FOR WATER PROOFING

(CONSULT A DESIGN PROFESSIONAL FOR FINAL DETAIL)

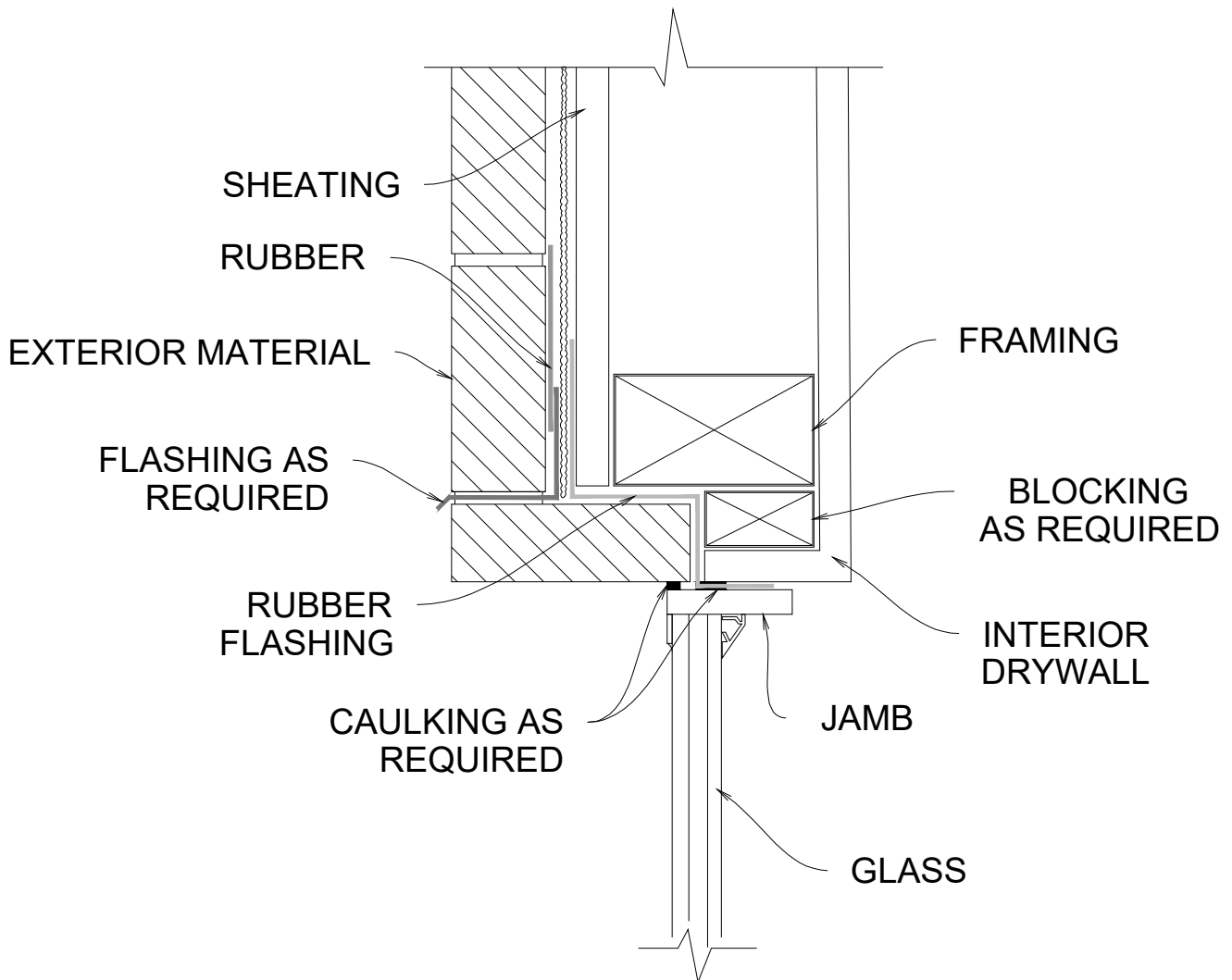

These details are recommendations only and for design consideration only.
 They should not be used for construction and a design professional should be consulted for final construction drawings.
 All units should be waterproofed both after the building wrap, and on completion of the exterior material.
 ADDITIONAL DETAILS PROVIDED ON REQUEST